

# NX-877 plus II

## PIC16F8xx/18F Microcontroller Experiment Board

---

Copyright 2004-2007 by Innovative Experiment Co.,Ltd.

### Feature

- Support PIC16F8xx/18F (PIC16F877A on-board). It comes with 8KWords Program memory, 20MHz clock and provides 33 I/O port
- Support HS oscillator modes
- Select mode RUN/PROGRAM with one switch
- Connect to PX-200 for downloading program with USB port via ICD2 jack
- RS-232 serial port interface circuit
- 3-digit multiplexed LED display
- 32-Bit LED monitor
- LCD connector
- 1Hz- 1kHz pulse generator
- 4 of 0-5V Voltage source for A/D experiment
- DS18B20 : 1-Wire Temperature sensor on-board.
- Matrix switch 4x3

### Packing List

- Experiment board
- Documentation
- PX-200 USB Flash PIC microcontroller In-System Programmer with USB cable and software in CD-ROM
- 12Vdc Adaptor
- 16x2 LCD module with cable
- RS-232 serial port cable
- Wire jumper box set

# 1. NX-877 plus II Schematic Description

## 1.1 Microcontroller section

The heart of this section is PIC16F877A microcontroller. It is programmed with via In-System Programming (ISP) via ICD2 jack by PX-200 programmer board (included in this package) and can select operation mode (Run/Program) by a MODE switch

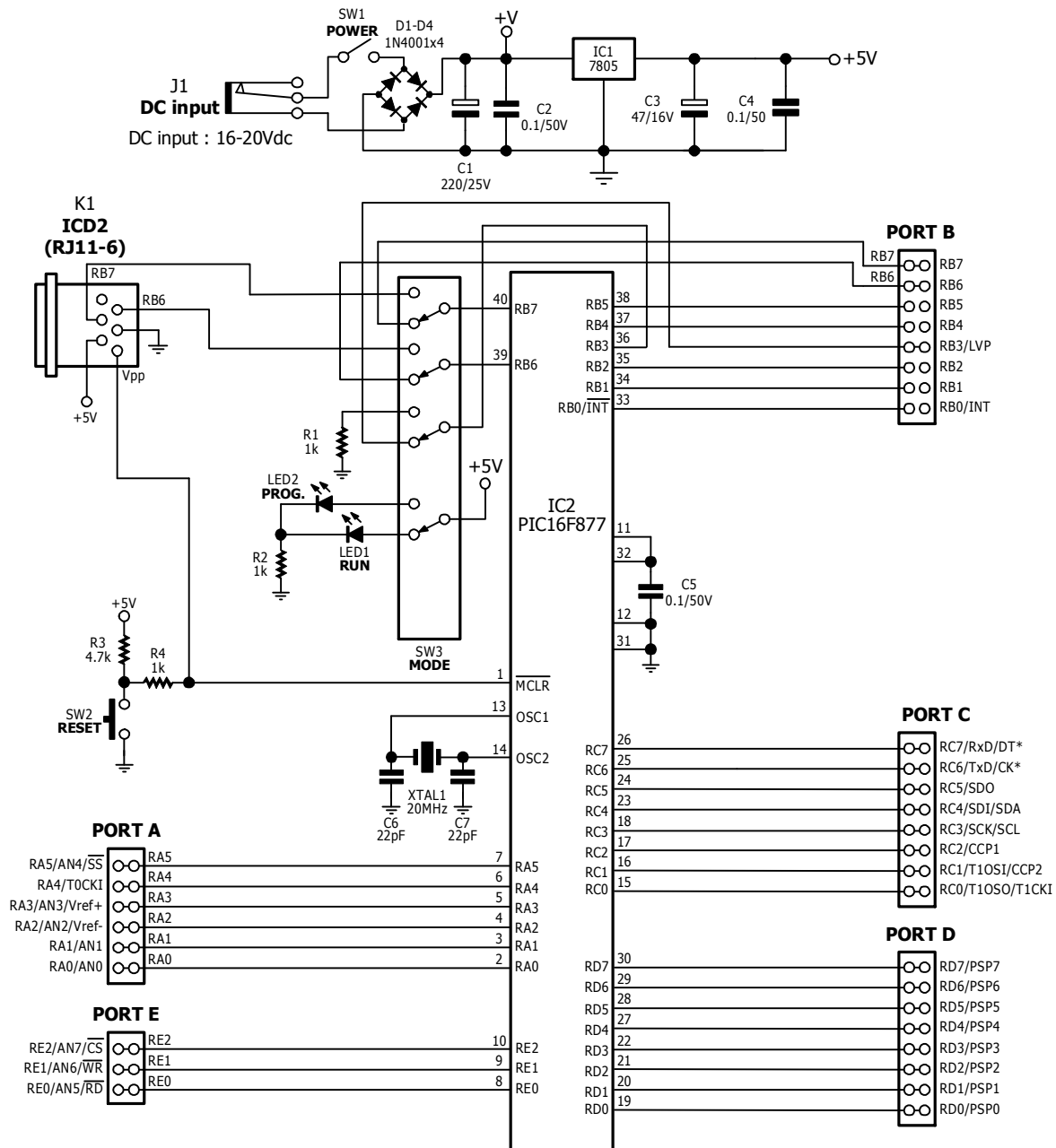

Experiment board provide 5 port groups, Port A (RA0-RA5), Port B (RB0-RB7), Port C (RC0-RC7), Port D (RD0-RD7 and Port E (RE0-RE2). However in 28-pin microcontroller cannot use Port D and E connector

Oscillator mode for microcontroller is HS mode, fixed frequency at 20MHz

On the experiment board provide +5V for supply the experiment circuit and all circuit on the experiment board.

## 1.2 LED monitor

On experiment board provides 32-bit of active high LED monitors . Each channel connectd current-limit resistor for protect LED current through.

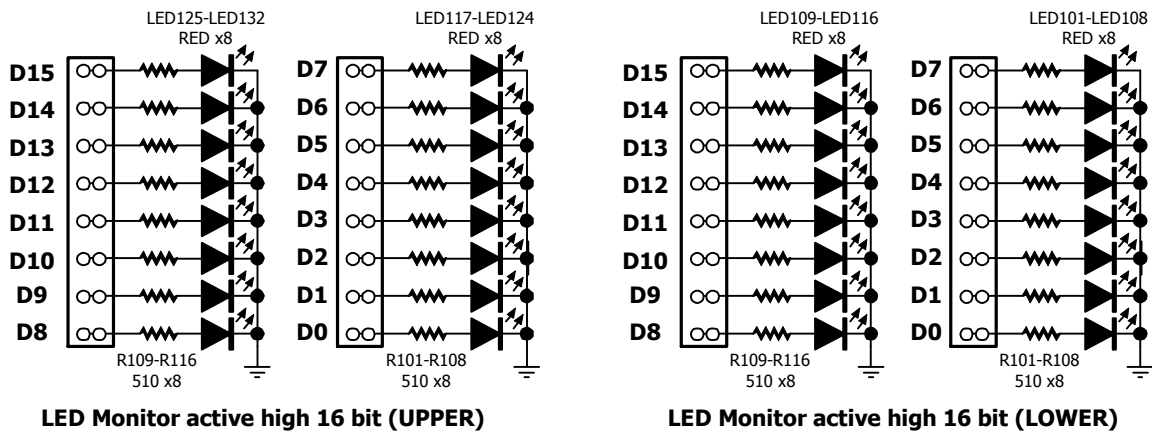

## 1.3 7-segment LED display

This board provides 3-digit of 7-segment common cathode LEDs. All LED connect in multiplex and connect current-limit resistor in each segment.

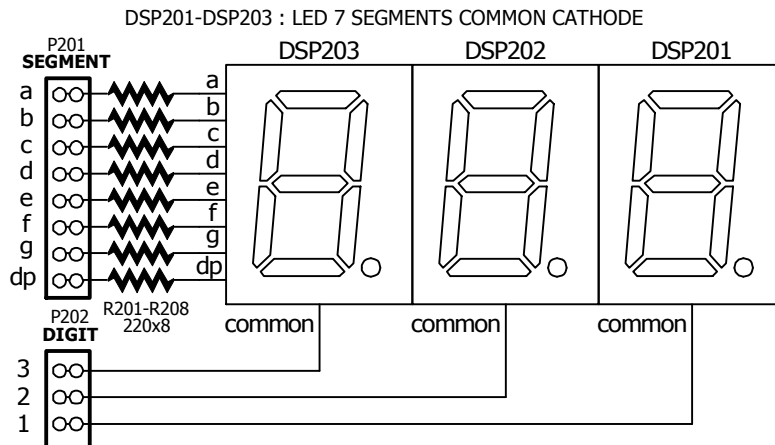

## 1.4 0 to +5V Reference Voltage Source

For support analog experiment, NX-877 plus experiment board provides 4 channels of 0 to 5V analog voltage source to supply analog voltage for ADC circuit.

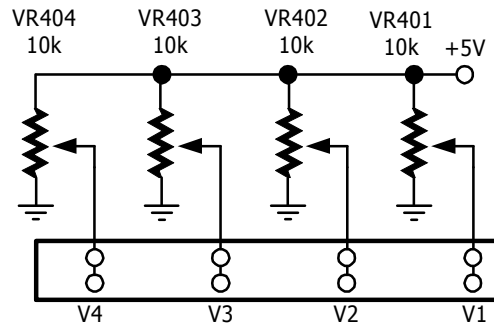

## 1.5 Switch input

Switch is the type of input device for microcontroller experiment. Four normally-open pushbuttons are made available via connectors. The buttons are wired in an active-low configuration, with an pull-up resistor.

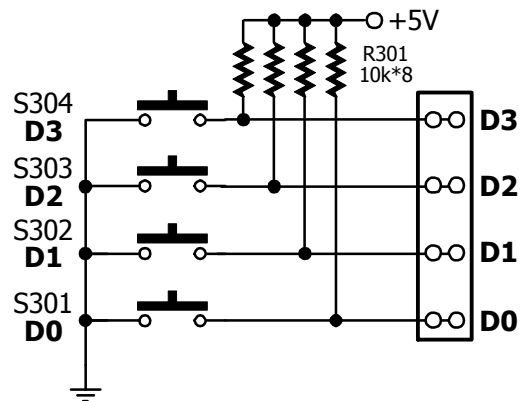

## 1.6 4x3 Matrix Switch or Keypad

This circuit consist of 12 push-button switch connect in matrix configuration. It is defined 4 rows and 3 columns. The pull-up resistors are connected at column lines. The switch position are defined in telephone keypad format, number 0 to 9, \* and #.

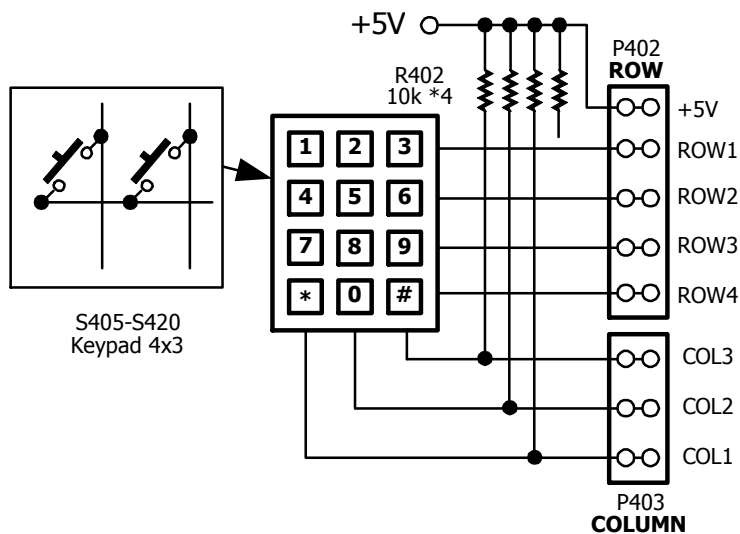

## 1.7 Pulse Generator

The NX-877 plus II experiment board's pulse generator provides a selectable square-wave output of 1 Hz, 10 Hz, 100 Hz, and 1 kHz. Frequency selection is by the push-button near the pulse generator output (an LED indicates current frequency). Be sure that the output of the pulse generator is connected to an input pin only, as this output is driven both high and low.

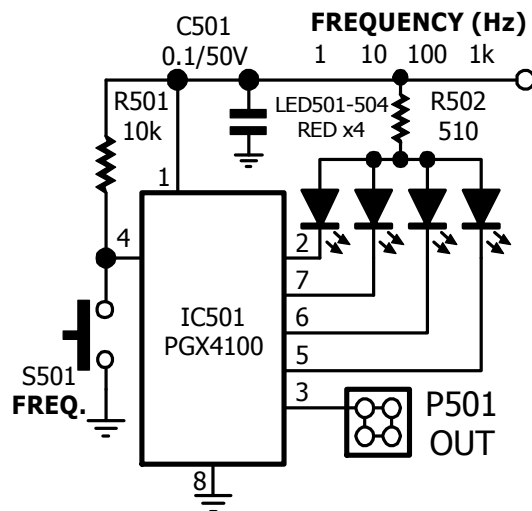

## 1.8 LCD module connector

At this connector can connect with 16-character 2-lines LCD module that bundle in experiment board set. It prepare variable resistor for LCD's contrast adjustment.

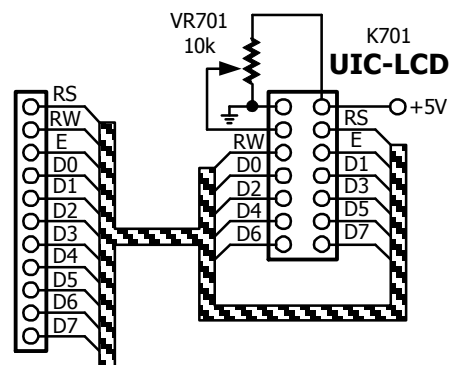

## 1.9 Piezo speaker

Sounding device on this experiment board is Piezo speaker. It may connect with 1 to 470mF electrolytic capacitor for amplify sound level. The piezospeaker has resonance frequency at 2 to 3 kHz. If the resonance frequency apply to the piezo speaker, it lounds maimum.

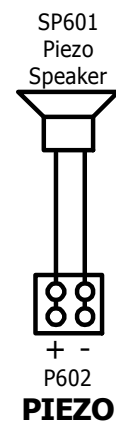

## 1.10 DS18B20 1-Wire Temperature sensor

For supporting the 1-Wire interface experiment, NX-877 plus II board provides a popular 1-Wire device; DS18B20 the temperature sensor include the pull-up resistor ready to interface with the microcontroller.

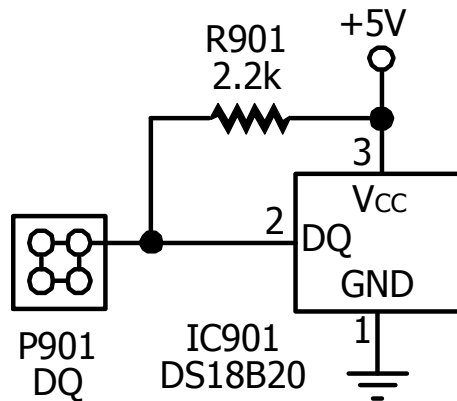

## 1.11 RS-232 circuit

RS-232 serial port interface to microcontroller, This experiment board provides the TxD and RxD pin to MAX232 circuit for interface serial port. Experimenter can interface RS-232 serial port very easy.

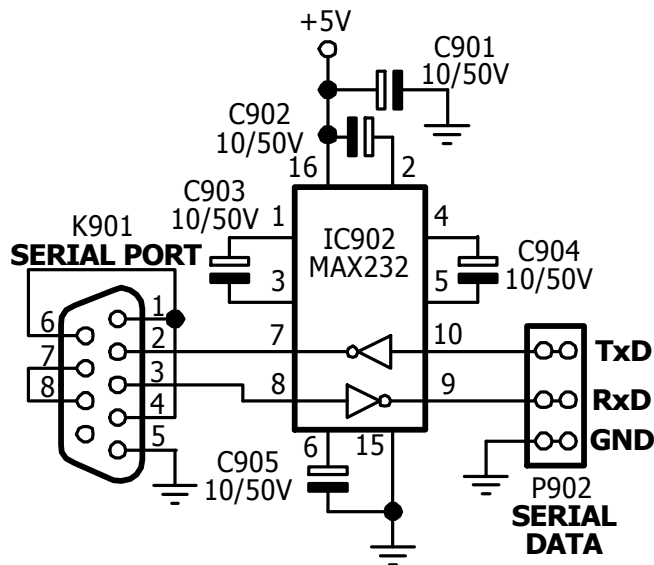

## 1.12 Preparing the Solderless Breadboard

Most experiments will involve components placed in the solderless breadboard. The breadboard on this experiment board size is 2.5x7 Inches and provides 800 point-contacts. Detail of breadboard shows in the figure below (the figure is example, size, number of row, point contacts may be change).

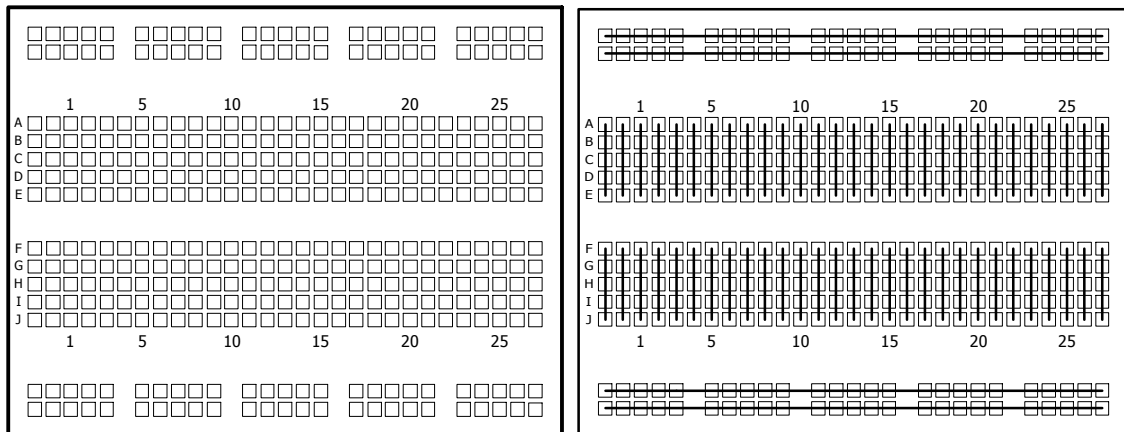

## 2. Using experiment board

### 2.1 Preparation

Before using, user must prepare some tool and software following :

2.1.1 Personal computer which install Window 95/98/ME/2000/XP, text editor program, MPLAB, MPASM and MicroPro software

**MPLAB** and **MPASM** are licenced by Microchip Technology , for more information please contact at <http://www.microchip.com> (included in CD-ROM when order NX-877 plus II)

**PICkit2™ Programming Software** are licenced by Microchip Technology , for more information please contact at <http://www.microchip.com> (included in CD-ROM when order NX-877 plus II)

Computer must available at least one USB port for connecting with PX-200 Programmer.

2.1.2 Write program, set beginning address at 0x0000 and save file in .ASM

2.1.3 Assembler .ASM file by MPASM with selected INHX8M type. So it will be HEX file

2.1.4 Prepare DC adpator 9 to 16V 500mA.

## 2.2 Procedure

2.2.1 Construct the circuit on breadboard of the NX-877 plus II board.

2.2.2 Connect PX-200 with USB port.

2.2.3 Open the PICkit2™ Programming Software.

2.2.4 Connect NX-877 plus board with PX-127 by ISP-6 cable at ISP jack.

2.2.5 Supply voltage to the NX-877 plus II board.

2.2.6 Press MODE switch for changing to PROGRAM mode, red LED is on.

2.2.7 Select the Device family command of the PICkit2™ Programming Software to Mid-range device. PX-200 will detect the target device automatically. The PIC16F877 or PIC16F877A microcontroller will be detected and ready to program.

2.2.8 Open the HEX file.

2.2.9 Erase and blank check data in the microcontroller.

2.2.10 Program all code into the microcontroller

2.2.11 Verify programming

2.2.12 After programming completed, press MODE switch to RUN mode. Microcontroller will run your program.

